

## Technical Datasheet

# Heavy Duty Cut Out MC300 Neutral,

## 300A Rated

### Overview

Board mounting enclosure to accept solid neutral links available with a choice of three terminal types for incoming or outgoing conductors.



### Features

- Robust all insulated construction
- Maximum incoming cable size 185mm<sup>2</sup>
- Drillings in both thumbscrews for 1mm locking wire
- Constant alignment neutral link prongs
- Cable clamp accepts circular or delta section conductors in copper or aluminium
- PVC membrane glands for cable entry and exits
- 4 x M6 pinching screws per conductor

**Note:** The equipment described in this data sheet must be installed by suitably qualified personnel according to applicable Local / National Wiring regulations currently in force.

### Construction

- Enclosure..... Polyester DMC
- Contacts..... Electro tin plated brass
- Cable grommets.....Flexible PVC
- Cable clamping screws..... Passivated steel
- Neutral Link.....Electro-tin plated copper

### Performance

- Incoming supply.....Max 300A
- Supply voltage.....415A a.c.
- Supply frequency..... 50-60Hz
- Rated insulation voltage.....690V ac
- Short circuit withstand strength.....18kA
- Flammability rating.....UL94 VO self-extinguishing 30 seconds at 960° C
- Tracking index (CTI).....>600

### Operator Protection

- Fuse handles in place..... IP3XB

### Conformity to Standards

- Complies with ENATS 37-2
- IP rating to BSEN 60529

### Dimensions

- Height.....167mm
- Width.....124mm
- Depth.....76mm

### Weight

- Net weight..... 1.41kg

### Fixing details

- Two 5mm countersunk holes in base of unit at 51mm centres

### Clamp Fitting Types



**Type 1 Clamp Fitting**  
For 35mm<sup>2</sup> to 120mm<sup>2</sup>

Torque Setting - 3.5Nm



**Type 2 Clamp Fitting**  
For 185mm<sup>2</sup>

Torque Setting - 3.5Nm



**Type 3 Clamp Fitting**  
For 95 mm<sup>2</sup>

Torque Setting - 3.5Nm

**General arrangement diagrams**  
(dims in mm)

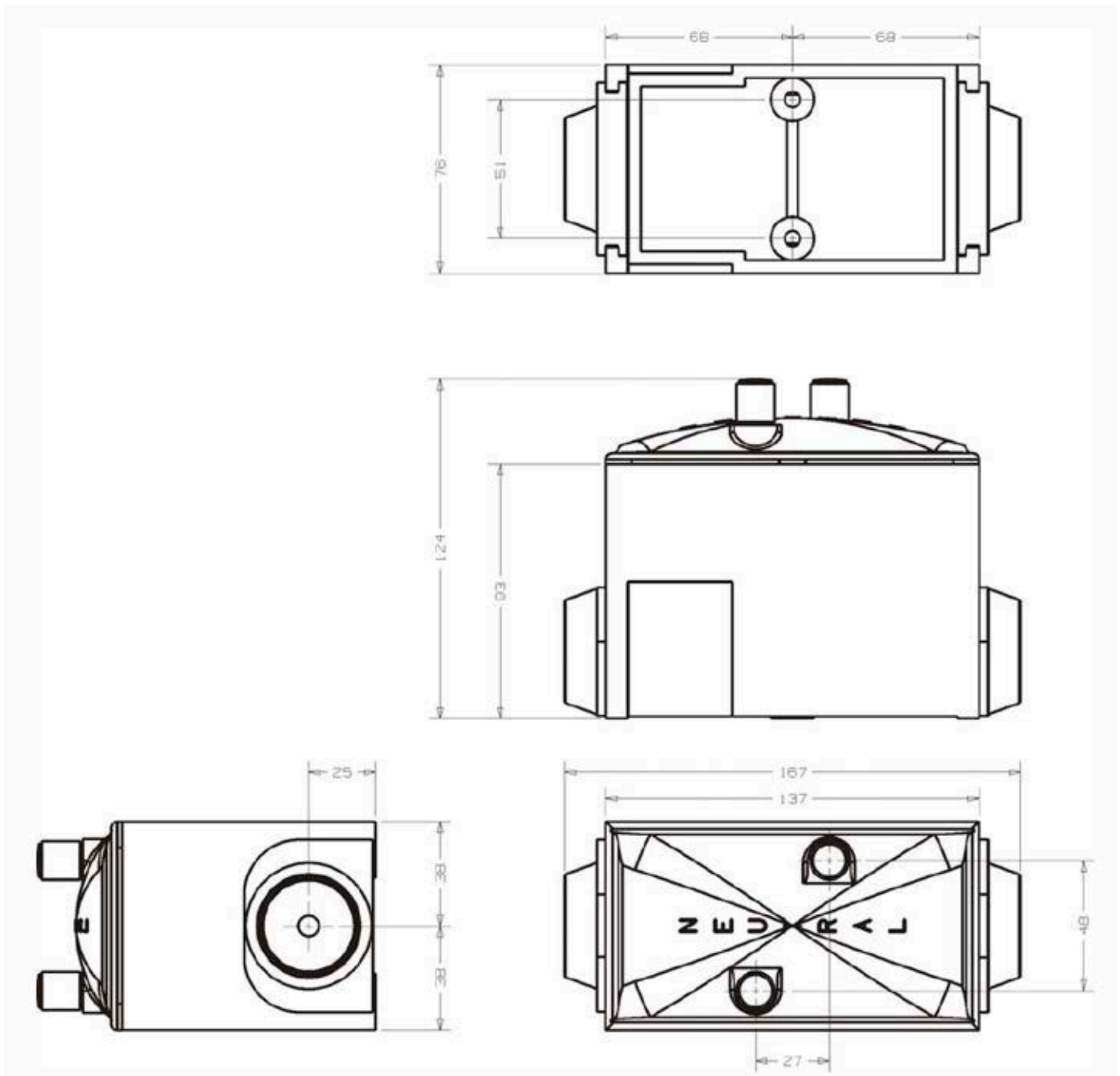

**Disclaimer:** Lucy Electric has a policy of continuous research and development thus accordingly reserves the right to change the design and specifications of its products without prior notice or liability.

[www.lucyelectric.com](http://www.lucyelectric.com)